

ROAMEO AP-1800

Access Point

RF (Radio Frequency) Considerations

When placing an access point, the antennas should be placed in such a way as to have great visibility over the area of desired coverage. This means mounting the access point to a high point, such as a ceiling or wall above most of the clutter and traffic of an area. If the access point has to be mounted in a tight space, keep the antennas at least 12 inches (30cm) from any metal.

Survey Implementation

Site Survey is a system feature used to plan and design the ROAMEO system. It provides crucial information such as wireless coverage and roaming coverage.

Using the Site Survey mode of the ROAMEO system, you are able to find access point coverage areas, even when obstacles are encountered, such as metal walls, reinforced concrete, metal-coated glass, etc.

Mounting the Access Point

Reference View

There are four (4) recommended ways to mount the ROAMEO AP-1800 access point unit: ceiling or wall-mounting, pole mounting, rail mounting, or as a free-standing installation (such as a table or shelf).

IMPORTANT: The mounting clamp kit is an optionally sold item.

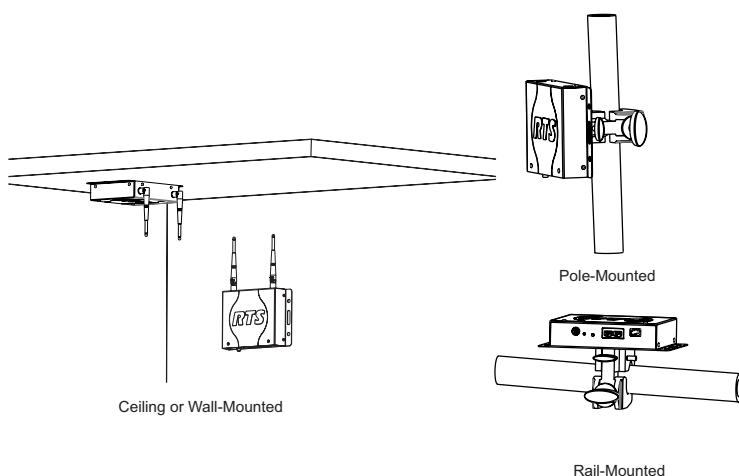

Antenna connection and placement

Antennas should be in the upright-most position for the best reception of signal. The antenna has a joint so you can adjust the angle, if needed.

To **attach the antennas to the ROAMEO AP-1800**, do the following:

1. Gently push the **antenna into the antenna connector** on the ROAMEO AP-1800. Take care to align the connector pin with the antenna pin hole.
2. Turn the **antenna clockwise to tighten** in place.

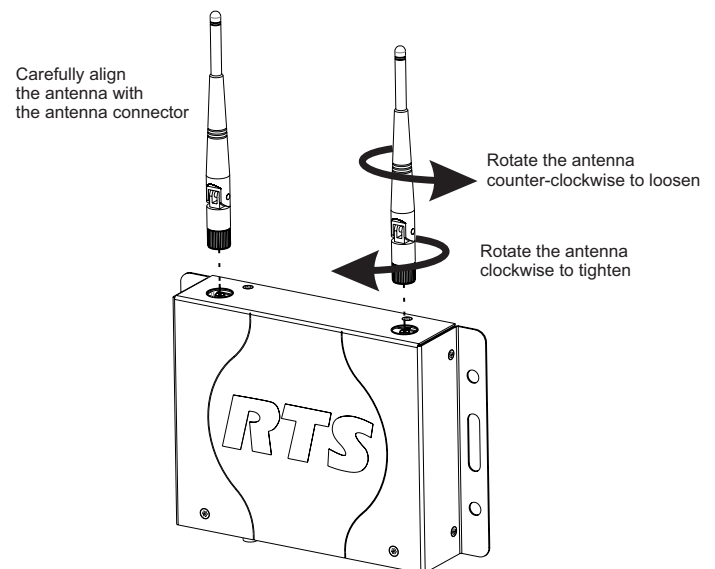

NOTE: For permanent antenna installation, it is recommended to tighten the antennas so they cannot come loose from vibration or if bumped.

Hand-tighten the antenna, and then using needle-nose pliers, grasp the serrated metal collar of the antenna and tighten about 1/16th inch (1.6 mm) more in the clockwise direction. This tightens the connector to about 5 lbf-in (0.56 Nm), which is the specification for a solid connection.

To **adjust the antennas for the best signal reception when the access point is mounted horizontally**, do the following:

- Carefully bend the **antenna 90° at the antenna joint until the antennas are aligned straight up or down.**

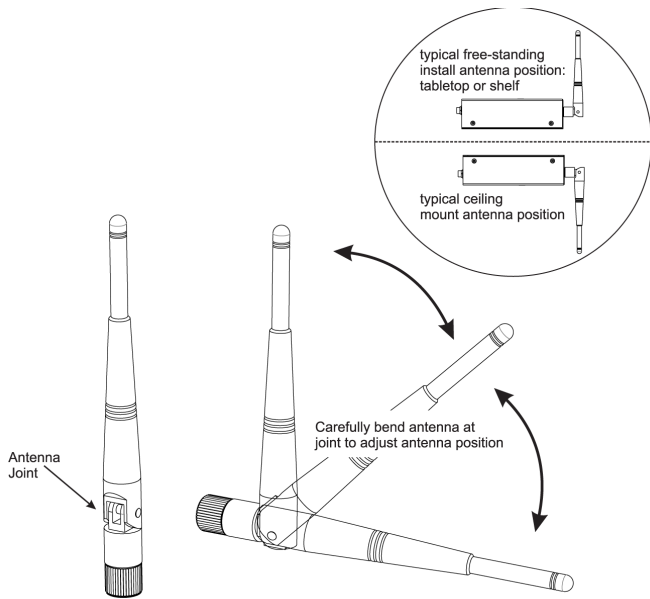

Wall or Ceiling Mounting

To **wall mount the ROAMEO AP-1800 access point**, do the following:

- Using the access point as a template and a pencil, mark the **four (4) hole locations** on the wall or ceiling.

NOTE: It may be necessary to predrill the holes or use screw anchors, depending on the material of the wall.

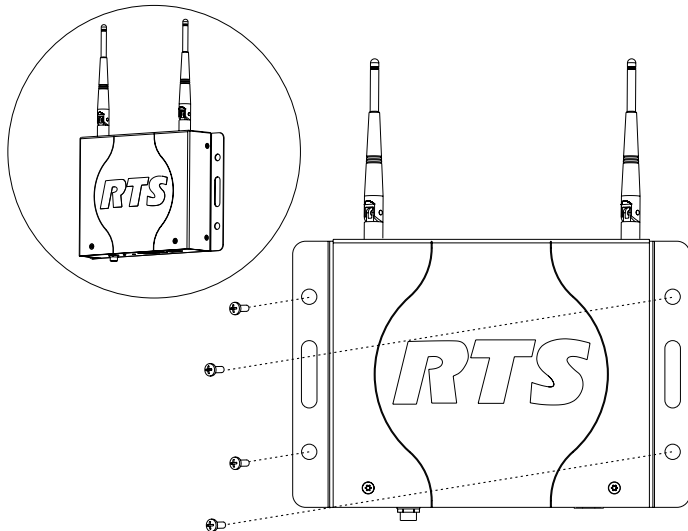

- Align the **AP-1800 in the position and placement desired.**
- Using a screw driver, drive the **screws into the predefined holes.**

Pole Mounting

To **pole mount the ROAMEO AP-1800 access point**, do the following:

- Align the **mounting clamp in the Pole Use Clamp Position** on the bottom of the AP-1800.

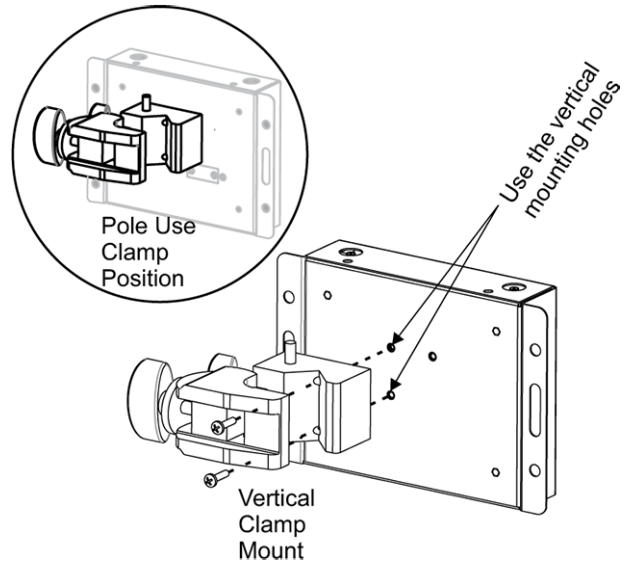

- Using the supplied screws from the mounting kit, attach the **mounting clamp to the AP-1800.**
- Fit the **mounting clamp around the pole** desired.

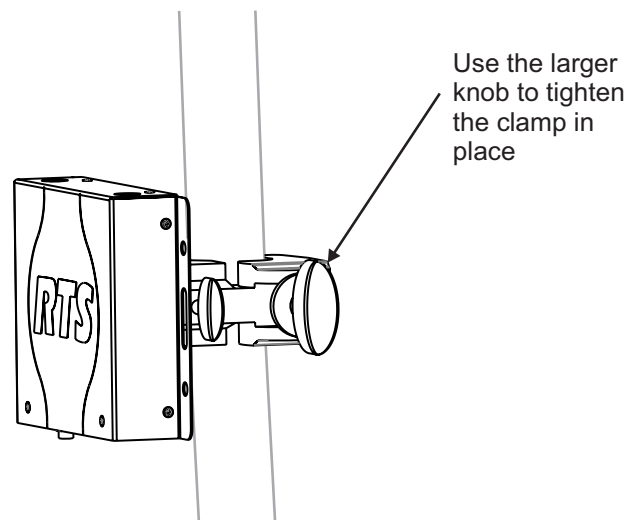

- Once in position, use the **adjustment knobs to tighten the clamp around the pole.**

Rail Mounting

To rail mount the ROAMEO AP-1800 access point, do the following:

1. Align the **mounting clamp in the Hand Rail Use Clamp Position** on the bottom of the AP-1800.
2. Using the supplied screws from the clamp kit, attach the **mounting clamp to the AP-1800**.

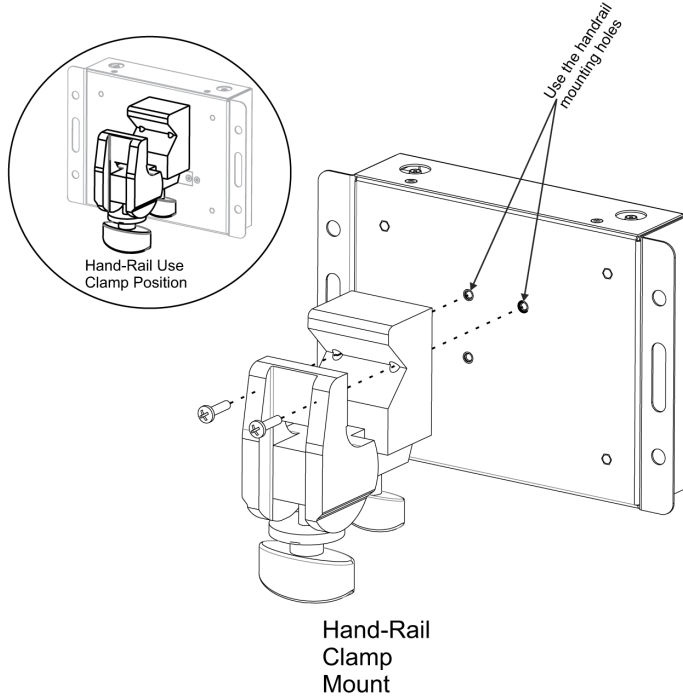

3. Fit the **mounting clamp around the rail** you want to mount the unit to.

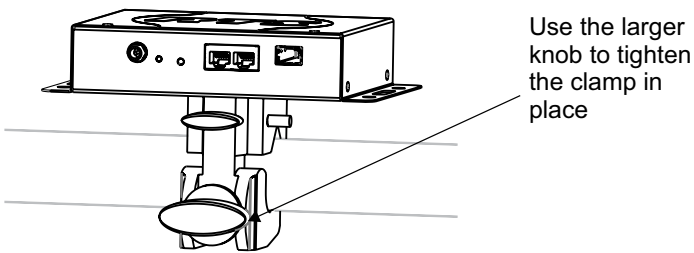

4. Once in position, use the **larger adjustment knob to tighten the clamp around the pole**.

Free-Standing Installation

Setting the AP-1800 unit on a table or shelf is commonly referred to as free-standing installation. When using this type of mounting, it is important to remember to position the antennas perpendicular to the unit (antennas in the air) for the best signal reception.

Mounting Surface	Materials Used	Qty
Drywall	Drywall screws	4
	Drywall anchors (as needed)	4
	1/4-inch (max.) Flat washer(as needed)	4
Concrete	1/4-inch (max.) Concrete screws	4
	Concrete anchors (as required)	4
	1/4-inch (max.) Flat washer(as needed)	4
Wood	1/4-inch (max.) Wood screws	4
	1/4-inch (max.) Flat washer(as needed)	4
Metal Surface	1/4-inch (max.) Sheet metal screws	4
	1/4-inch (max.) Flat washer(as needed)	4
	OR	
	Self-tapping or Self-drilling sheet metal screws, 1/4-inch (max.)	4
	OR	
	Machine screw, 1/4-inch (max.)	4
Machine nut or drilled and tapped holes		
1/4-inch (max.) Flat washer(as needed)	4	
Rack Frame	10-32 Rackmount Screws	2 to 4
	1/4-inch (max.) Flat washer(as needed)	2 to 4
	OR	
	10-32 Truss Head Rackmount Screws	2 to 4.
Building Structure Member (roof trusses, etc)	1/4-inch (max.) U-bolts	4
	1/4-inch (max.) Flat washer(as needed)	4
	1/4-inch (max.) Machine nuts	4
	OR	
	See Metal Surface Mounting	

Set Up for Site Survey

Requirements

- AP-1800 Access Point and Power Supply
- TR-1800 Beltpack and Battery
- Computer with an Ethernet port and IPedit Software installed
- Standard Ethernet Cable

Prepare the Hardware

- Verify the **antennas** are mounted on the access point.

Use IPedit to Configure the AP-1800 Access Point

NOTE: If the AP-1800 you plan to use is already part of an operating system, then none of the following configuration is required.

Network Configuration

NOTE: By Default, the AP-1800 is configured to automatically receive an IP Address (link-local or DHCP). If the network addressing scheme of the AP-1800 is unknown, a factory restore sets the unit back to the default configuration.

- Link-Local addressing:
If the AP-1800 and computer are connected directly, the computer network configuration should be changed to a link-local address (see instructions below).
- DHCP Server addressing:
If the AP-1800 and computer are connected to a network with DHCP server, the computer should be set up to receive an IP Address automatically.
- Static-IP Address addressing:
If the AP-1800 uses static IP Address addressing, the computer network configuration should be changed to an IP Address belonging to the same network.

Set the Computer to a Link-Local IP Address

To **set the computer to a Link-Local IP Address**, do the following:

NOTE: These instructions detail a typical setup for the Windows 7 platform.

1. From the Start menu, select **Control Panel**.
2. Click **Network and Internet**.
The Network and Internet window appears.
3. Click **Network and Sharing Center**.
The Network and Sharing Center window appears.
4. Click **Change Adapter Settings**.
The Network Connections window appears.
5. Double-click **Local Area Connection**.
The Local Area Connection Status Properties window appears.
6. From the connection list, select **Internet Protocol Version 4 (TCP/IPv4)**.

7. Click the **Properties** button.
The Internet Protocol Version 4 (TCP/IPv4) Properties window appears.
8. Select the **Use the following IP Address** check box.
The IP fields become active
9. In the IP Address: field, enter **169.254.0.1**.

NOTE: If the AP-1800 you plan to use has been connected to a Matrix system in the past or has been assigned a fixed IP Address already, then assigning the computer a Link-Local Address will not work. If you know the AP-1800's IP Address, configure the computer to be in its network. If you do not know the IP Address, then reset the AP-1800 back to a Link Local Address by doing a factory reset. For more information on performing a factory reset, see the ROAMEO Technical Manual.

10. In the subnet mask: field, enter **255.255.0.0**.
11. Click the **OK** button to exit the Internet Protocol Properties window.
12. Click the **Close** button to exit the Local Area Connection Properties window.

Add the Access Point to IPedit

To **add the access point to IPedit**, do the following:

1. Start **IPedit**.
2. From the Devices menu, select **Add**.
The Add Devices window appears.
3. From the Available Devices pane, select the **Access Point**.
The Add button becomes active.
4. Click **Add**.
The AP-1800 appears in the device catalog in the left panel.
5. Click **Done**.
The Add Devices window closes. The AP-1800 appears in the Device Catalog.

Configure the Access Point

IMPORTANT: The user must be signed into IPedit with network administrator rights to complete these instructions

To **configure the Access Point with IPedit**, do the following:

1. From the Device Catalog on the left, select the **AP-1800**.
The Device Information fields populate.
2. In the Description field, enter a **unique description** for the access point.
3. In the Version field, verify the **version information** is correct. The latest software can be obtained from www.rtsintercoms.com.
4. If using a static IP Address, verify the **IP Address is correct**. Select the
5. Select the **Disable RSTP** check box to disable the RSTP

protocol, if desired.

NOTE: If RSTP is enabled and the connection has a switch, then the switch must also have RSTP enabled.

DECT Information

6. In the System ID field, enter the **system ID** for the access point. This field accepts a 3-digit hexadecimal number. By default, this field is set to *B2B*.

NOTE: All access points in a system must have the same System ID.

7. In the AP ID field, enter the **unique AP ID** for the access point. The range for this field is *1-255*.

8. Select the **Sync Master check box**. When doing a site survey with a single AP-1800, it must be set to a Sync Master unit. If doing a site survey of a system, leave this set for the system.

NOTE: There can be only one master in each system.

9. In the PIN field, enter the **PIN** of the access point. By default, this field is set to 0000.

10. From the Zone drop down menu, select the **zone** the access point is assigned.

11. From the CODEC drop down menu, select the **CODEC** the access point is running.

IMPORTANT: The CODEC of the access point is either G.722 (wideband) or G.726 (narrowband). A system **MUST** be all G.722 or G.726.

Channel Configuration Pane

12. From the column headings, select the **channel** to configure (for example, Channel 1, etc.).

IMPORTANT: With CODEC G.722, five channels are available for configuration. With CODEC G.726 10 channels are available for configuration.

TIP: When setting up a multiple access point system, consider leaving one or two channels open for additional beltacks and distribute the existing beltacks equally among the access points.

13. In the Channel Description field, enter a **channel description**, if applicable.

To assign the beltack to a connected Matrix system, follow step 14 through step 16 to configure the access point and OMI channels. For Site Survey without a Matrix, proceed to step 17

14. From the Description Type drop down menu, select the **OMI card** to which the channel is connected.

15. In the Destination Device Name field, enter the **name of the OMI card** to which the channel is connected.

OR

Click the **Browse button**.

The Discovered Devices window appears.

- a. Expand the **tree** to view the available destination devices.
- b. From the expanded tree, select the **destination device**.
- c. Click **OK**.

The Discovered Devices window closes.

16. From the Destination Channel drop down menu, select the **destination channel** to which the channel is connected.

17. In the DECT BPID, enter the **beltack ID** to assign to that channel.

18. In the DECT Zone Selections field, enter the **zone** the beltack is permitted to operate (the default is zone 1).
OR

From the DECT Zone drop down menu, select the **check box next to each zone** to assign the beltack.

NOTE: At least one zone must be selected for the beltack. Any combination of zone may be selected.



19. From the Changes menu, select **Send**.

20. From the File menu, select **Save**.

Subscribe the TR-1800 to the AP-1800

To **subscribe the TR-1800 to the AP-1800**, do the following:

IMPORTANT: Be sure the beltack is within 40 feet (12 meters) of the AP-1800.

1. With the AP running, power-on the **TR-1800**.
The front color display panel activates.
2. Press the **Menu button twice**.
The beltack main menu appears.
3. Using the up and down arrow buttons, navigate to the **System Setup icon**. 
4. Press the **Select button**.
The Subscription Setup menu appears.
5. Using the up and down arrow buttons, navigate to the **sub-system setup icon**. 
6. Press the **Select button**.
The Enter System ID screen appears. The default System ID is B2B.
7. Using the up and down arrows, enter the **first character of the access point system ID**.
8. Press the **Select button**.
The focus moves to the next character space in the system ID.
9. Repeat **steps 8 and 9** until the system ID is entered completely.
10. Once the system ID is entered, press the **Select button**.
The Enter PIN screen appears.
11. Using the up and down arrows, enter the **first number of the access point pin number**. (The default is 0000).
12. Press the **Select button**.
The focus moves to the next character space in the PIN number.
13. Repeat **steps 12 and 13** until the PIN number is entered completely.
The Home screen appears in the front display. The DECT connection icon and the RSSI icon become active.

Performing a Site Survey

A site survey is performed to determine the placement of access points to ensure RF coverage of the desired area. A beltback, communicating with an access point at a test location, is set to the site survey screen where **RSSI** (Received Signal Strength Indication) and **QF** (Quality Factor) are both used to find the RF coverage area.

Prerequisites



- Have a beltback that has been successfully subscribed to an access point.
- Have a site map or blueprint of the building that can be marked up.
- Power can be supplied to the access point at the possible test locations either by using power extension cables or battery power.
 - For battery power 12VDC @ 0.600 Amps must be available to the access point. A charged 12VDC battery rated for at least 2.4 Amp-hours is recommended for a typical site survey length of time.
 - The input connector required for an access point is a 13.8mm long, female barrel, 2.5mm x 5.5mm connector.

NOTE: The unit is marked 1.5 Amps. This is an upper limit set to handle peak loads when fully loaded. When doing site surveys, an access point is not heavily loaded.

To **perform a site survey**, do the following:

1. Place the **access point** in the location to be tested for coverage.
2. Power up the **access point**.
When the power light turns solid green, the access point is ready.
3. Power up the **beltback**.
The splash screen momentarily displays and then the home screen appears.

NOTE:  When the beltback finishes booting, the home screen indicates a wireless connection. If the wireless connection does not display, verify settings in the "Setup for a Site Survey" section.

4. Press the **Menu button**.
The beltback main menu appears.
5. Using the up and down arrow buttons, navigate to the **System Setup icon**.
6. Press the **SELECT button**.
The beltback system setup menu appears.
7. Using the up and  down arrow buttons, navigate to the **Site Survey icon**. 
8. Press the **SELECT button**.
The site survey screen appears.

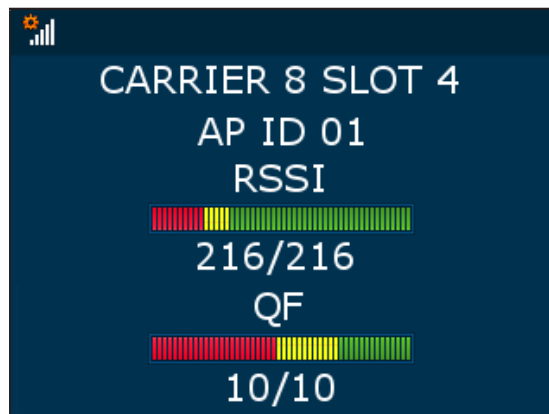

CARRIER -	Current RF carrier of the access point (this may change from time to time)
SLOT -	Current time slot on the RF carrier the access point to beltback packets are on (this may change from time to time)
AP ID -	Access Point Identification
RSSI -	Radio Signal Strength Indication
QF -	Quality Factor. This is representative of the number of packets received out of packets sent

Meaning of RSSI

RSSI	Color	Description
0-47	Red	Weak - poor to no reception in area
48-70	Yellow	Marginal - some dropouts of audio in area
71-216	Green	Strong - good RF coverage

Meaning of QF

QF	Color	Description
0-4	Red	Weak - too many dropouts in the area
5-6	Yellow	Marginal - some dropouts of audio in area
7-10	Green	Strong - good RF coverage

9. Mark the **access point's location on the building layout diagram**.

10. **Walk around** with the beltback throughout the area(s) of interest while looking at the site survey screen.

NOTE: If performing a survey of an installed system, monitor the AP ID displayed on the site survey screen to view where coverage area boundaries exist.

11. Record the **RSSI** and **QF number** on the building layout diagram at several locations throughout the area of interest.

GOOD COVERAGE AREA DEFINITION:
 RSSI = 71 – 216, Site survey bar in the green.
 QF = 7 -10, Site survey bar in the green.
 If the two indications are different, always use the worst case of the RSSI and QF indications for defining a good coverage area. Example: QF = 10 and RSSI = 71, use the RSSI level as the cutoff for the good coverage area.

12. When you have collected enough data points, draw a **line on the building layout**, using the coverage limits as shown in the good coverage area definition information

Try other access point locations to to improve the RF coverage in the desired area, if needed.

If setting up a roaming system, ensure good overlap of coverage areas of the access points. Good roaming between access point areas requires overlap of coverage for error-free roaming.

The access points that support roaming beltpacks should have an RSSI of >80 from each access point involved in the overlap to provide error-free roaming.

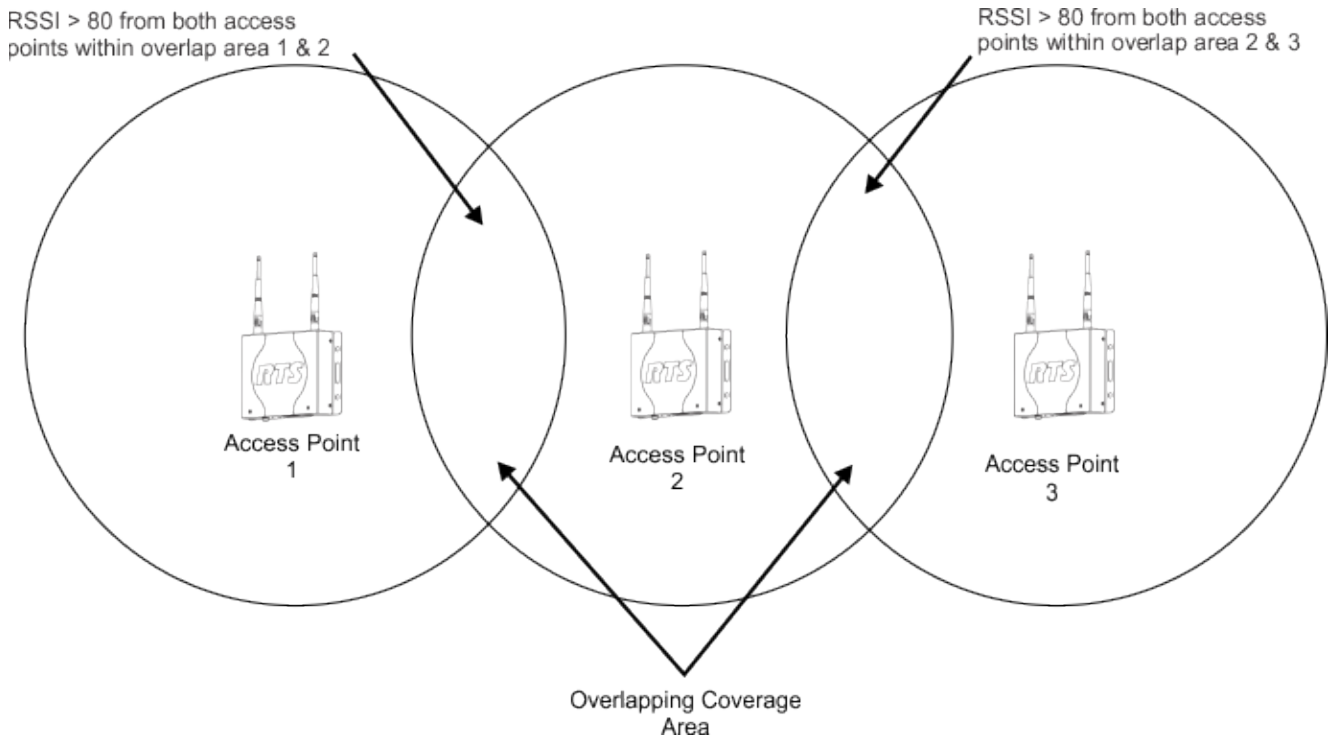

In high density beltpack areas where more than six wideband access points may be required, some access points may not detect an RF carrier already in use which can result in roaming issues. The system works best if these scenarios are avoided by designing high density areas with good access point overlap. The following figure shows how all seven access points can detect and coordinate carriers and time slots with each other, even when there are more than six devices present. The 112 RSSI contour limit can be measured by a beltpack using the site survey screen when testing an access point location.

